

GNESD

GLOBAL NETWORK ON ENERGY FOR SUSTAINABLE DEVELOPMENT

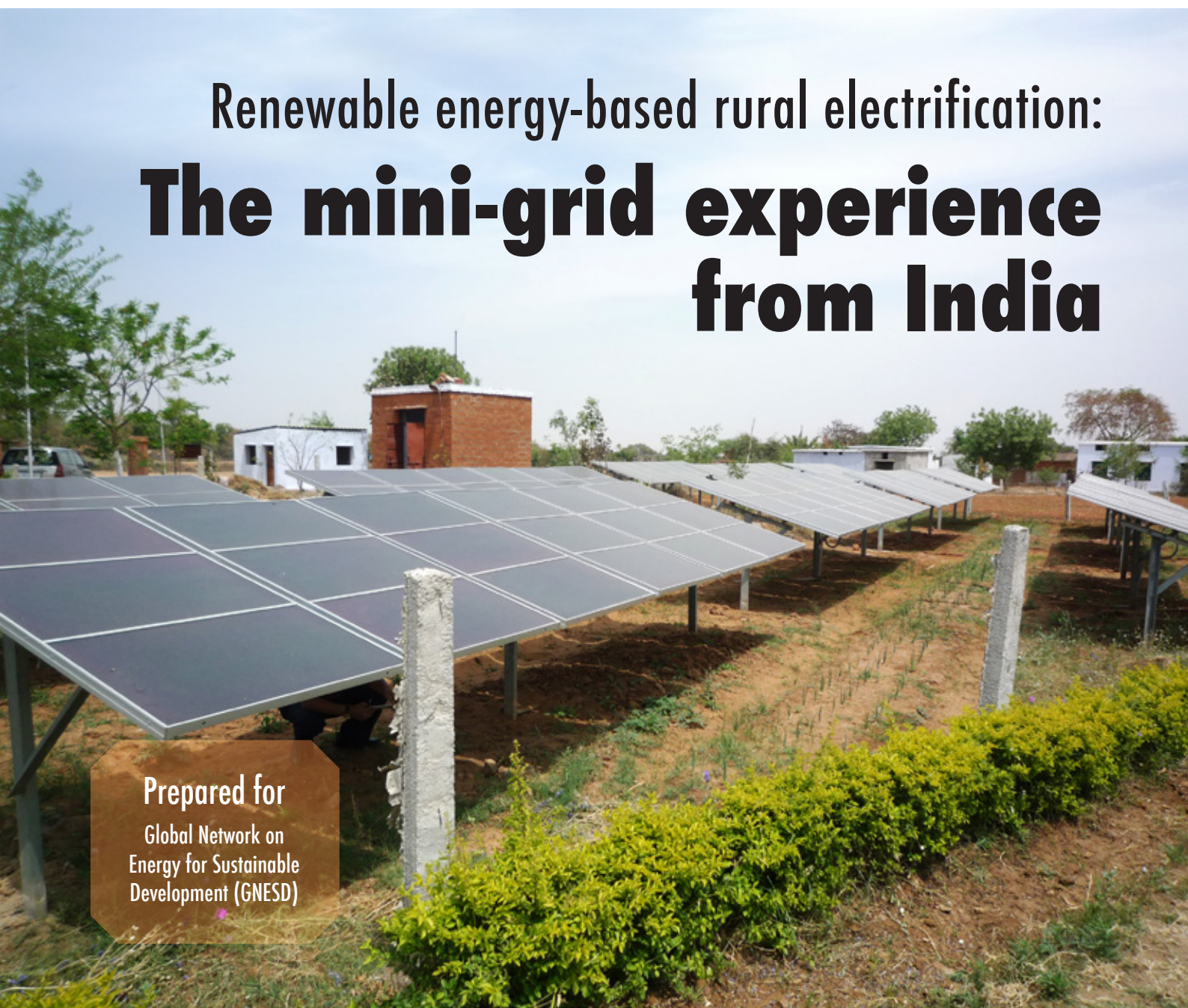

Renewable energy-based rural electrification: **The mini-grid experience from India**



Prepared for
Global Network on
Energy for Sustainable
Development (GNESD)



SUSTAINABLE
ENERGY FOR ALL

GNESD



Renewable energy-based rural electrification:
**The mini-grid experience
from India**

Prepared for
Global Network on Energy for Sustainable Development (GNESD)

Authors
Debajit Palit and Gopal K Sarangi



Design, layout and production by Phoenix Design Aid A/S, Denmark. ISO 14001/ISO 9000 certified and approved CO2 neutral company – www.phoenixdesignaid.com.

Printed on environmentally friendly paper (without chlorine) with vegetable-based inks. The printed matter is recyclable.

Global Network on Energy for Sustainable Development (GNESD)

GNESD is a UNEP-facilitated network of Centres of Excellence dedicated to improving energy access for the poor in developing countries, and helping those countries with energy access policy recommendations to achieve their Millennium Development Goals (MDGs). The current member Centres of Excellence from developing and emerging economies include China, India, Thailand, Brazil, Argentina, Mexico, South Africa, Kenya, Senegal, Tunisia and Lebanon. The network members are all renowned institutions in energy topics. GNESD membership facilitates coordinated analytical work, the exchange of information and policy analysis on environmentally benign energy-policy options relevant to national and regional governments.

Scientific research findings produced by the network are freely available to governments and regional organizations for formulating policies and programmes. The private sector can also use these findings in their efforts to attract investments.

GNESD activities are based on the firm belief that access to affordable, modern energy services is a pre-requisite for sustainable development and the alleviation of poverty. These activities are designed to:

- » strengthen South-South knowledge exchange and collaboration on environmentally benign energy access issues;
- » create a communications infrastructure that makes it easier for member centres to share experiences and draw on each other's strengths, expertise and skills; and
- » engage member centres more actively in national/ regional policy dialogue and outreach activities.

GNESD is one of several Type II partnerships in the field of energy that were launched at the World Summit on Sustainable Development (WSSD) in Johannesburg, September 2002.

GNESD is funded primarily by the governments of Germany and Denmark. In the past it has also obtained support from France, Italy and the United Kingdom. The network also receives support from the UN Foundation, UNDP and REEEP.

The GNESD Secretariat is hosted at the UNEP DTU Partnership.

This publication may be reproduced in whole or in part and in any form for educational and non-profit purposes without special permission from the

copyright holder, provided it is acknowledged. GNESD would appreciate receiving notification or a copy of any publication that uses this publication as a reference. No part of this publication may be made for resale or for any other commercial purpose whatsoever without prior permission in writing from GNESD. The opinions and recommendations expressed in this report are those of the authors and do not necessarily reflect those of UNEP, UN-Energy and GNESD. The designations employed and the presentation of the material in this publication do not imply the expression of any opinion whatsoever on the part of UNEP, UN-Energy or GNESD concerning the legal status of any country, territory, city, or area or of its authorities. References to different sources have been made in this document; for full references please refer to the full country reports.

Full citation

GNESD. 2014 Renewable energy-based rural electrification: The Mini-Grid Experience from India. New Delhi: Prepared by The Energy and Resources Institute (TERI) for the Global Network on Energy for Sustainable Development (GNESD).

This publication and other GNESD publications can be downloaded from www.gnesd.org.

ISBN: 978-87-93130-17-3

For more information

For more information on this document and additional copies, please contact:

Emmanuel Ackom
Programme Manager

Global Network on Energy for Sustainable Development (facilitated by UNEP)
UNEP DTU Partnership

UN City, Marmorvej 51, 2100 Copenhagen
Tel.: +45 4533 5289
Email: emac@dtu.dk
www.gnesd.org

Table of Contents

Introduction	9
Study objectives and approach	11
Assessment of renewable energy-based mini-grids in India	12
Policies and regulation	13
Technical features and capacity	15
Service delivery models	16
Financing	21
Tariffs	22
Operation and management	23
Community participation and capacity building	24
Challenges in dissemination of mini-grids	25
Conclusions and lessons learned	27
Institutional	27
Choice of technology	27
Cluster approach for implementation	29
Enabling policy and regulatory environment	29
Local capacity-building	30
References	31

List of Abbreviations

A-B-C	Anchor, Business groups and Community members
AMC	Annual Maintenance Contract
BM	Built and Maintain
BOM	Built-Operate-Maintain
BOOM	Built-Owned-Operated-Maintained
CREDA	Chhattisgarh Renewable Energy Development Agency
CSR	Corporate Social Responsibility
DDG	Decentralised Distributed Generation
DISCOM	Electricity Distribution Company
ESP	Energy Service Provider
GNESD	Global Network on Energy for Sustainable Development
HPS	Husk Power Systems
JNNSM	Jawaharlal Nehru National Solar Mission
MGP	Mera Gao Micro Grid Power
MNRE	Ministry of New and Renewable Energy
NGO	Non-Governmental Organisation
PIA	Project Implementation Agency
REC	Rural Electricity Co-operatives
RGGVY	Rahul Gandhi Grameen Vidyutikaran Yojana
RVEP	Remote Village Electrification Programme
SCS	Solar Charging Stations
SHS	Solar Home Systems
VDC	Village Development Committee
VEC	Village Energy Committee
VESP	Village Energy Security Programme
WBREDA	West Bengal Renewable Energy Development Agency

Foreword

The predominant form of electrification in India, as in the rest of the world, has been and still is connection to national grids. Still there remain significant populations in remote areas where the grid has not reached, and where decentralised options are attractive. Combined with cost decreases and improvements in the reliability of the technology, renewable energy forms such as solar PV, biogas and small hydro are becoming increasingly relevant to fill the gap in electricity supply to areas that are not yet connected to main grids.

The development of mini-grids, based on such renewable energy sources, has been particularly successful in India. This report provides a review of experience of mini-grids in India with specific references to successful cases.

The study was partially funded by the International Renewable Energy Agency (IRENA) whom the GNESD secretariat gratefully thanks for support.

Emmanuel Ackom

John M. Christensen

Gordon A. Mackenzie

GNESD Secretariat
UNEP DTU Partnership
Denmark

Introduction

India is predominantly a rural country with approximately 70 percent of the total population living in villages. Thus, India's economic and social development is inherently linked to growth in the rural sector. In order to contribute to India's overall development, the rural sector must have access to modern forms of energy such as electricity. Despite efforts by the federal and provincial governments in India to improve electricity access and services during the last five decades, household electrification levels and electricity availability continues to lag behind the global average. While the global average electrification rate in 2011 was 81.9 percent, the average electrification rate for India stood at 75.3 percent, with rural area having only 66.9 percent (IEA, 2013). In absolute terms, almost 77 million households in India were living without electricity in 2011 (Figure 1). The lower household electrification level reflects that historically the electrification rate has been measured as a percentage of electrified villages with grid extensions to any point within village revenue boundaries. This was irrespective of whether any household was actually connected, and thus did not provide a true percentage of connected households. While the definition of an electrified village was modified in 2004 by the introduction of criteria such as the requirement of village electricity infrastructure and a minimum of 10 percent household coverage etc., this is still limited to the target of achieving physical access without providing adequate importance to the delivery and reliability of the electricity services. The slow pace of electrification is also attributed to sporadic policy focus in the past (Bhattacharyya, 2006). Besides, a host of other issues such as political economy concerns (Rao, 2013) and constraints at the institutional and organisation levels (Cust et al., 2007) etc. also have contributed to the slow progress of rural electrification in India.

Figure 1: Electricity access in India (Census of India 2011)

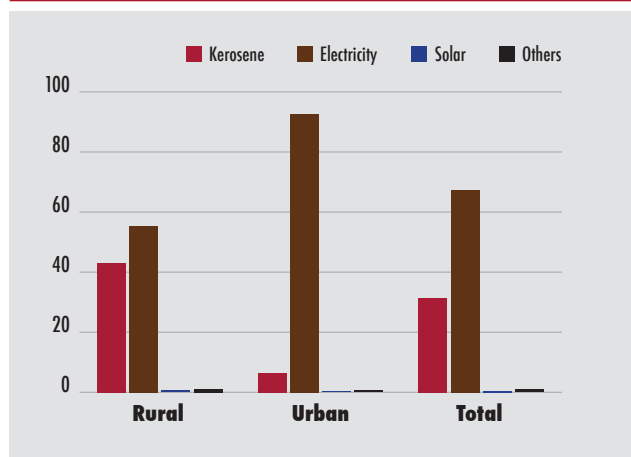

Grid-based electrification has been the predominant form for electrification in India, covering almost 94.5 percent of the inhabited area. In addition, renewable energy-based off-grid and decentralised technologies¹ have also been disseminated in areas that are either inaccessible for grid connectivity or are part of hamlets that are not recognised

1 ESMAP defines the decentralized system as “an alternative approach to production of electricity and the undertaking and management of electrification project that may be grid connected or not i.e. off-grid. An off-grid electricity supply can take two forms – individual product-based solutions and community or collective network-based solutions. Individual solutions involve sale of a product (or sometimes service) that enables individual households to produce a small quantity of electrical energy (at low *voltage*) to meet basic household needs such as lighting or providing energy for charging mobile or running simple electrical appliances such as a television, fan etc. Community or collective solutions serve a cluster of households or an entire village and provide electricity generally by generating from a diverse range of small local generators, with or without its own storage, and distributing it amongst the consumers. They are commonly called mini-grid or micro grid depending on capacity and scale of operation.



Electricity tower in Nagpur, India. Photo credit: Harshad Sharma, Flickr, Creative Commons.

as villages as per the national census record (Palit and Chaurey, 2011). The common renewable energy-based technologies used for electrification of remote areas are solar PV, biomass gasifier and mini/micro hydro. Renewable energy-based decentralised technologies, such as solar home systems (SHS) and solar charging stations (SCS) have been deployed in grid-connected areas where availability of reliable and adequate electricity has been a concern. The state renewable energy development agencies, estab-

lished by the state governments and working under the aegis of the Indian Ministry of New and Renewable Energy (MNRE), have largely implemented these initiatives. In addition, NGOs have implemented numerous pilot projects by raising funds from donor agencies and receiving funds from corporate social responsibility (CSR) initiatives. Recent trends also indicate that the off-grid energy sector is increasingly emerging as a focus for private investors in starting new business ventures.

Study objectives and approach

This study investigates renewable energy-based rural electrification in India, with a specific focus on the mini and micro-grid experiences. Specific references are made to solar PV and biomass-based technologies implemented under publicly supported programmes like the Remote Village Electrification programme (RVEP) and the Village Energy Security programme (VESP) of MNRE. Under publicly supported programmes, two different variants of mini-grids promoted under two different settings are examined here in depth. These are the Sunderbans mini-grid model promoted by the West Bengal Renewable Energy Development Agency (WBREDA) and the Chhattisgarh mini-grid model promoted by the Chhattisgarh Renewable Energy Development Agency (CREDA). While the renewable energy-based mini-grids were pioneered in the Sunderbans during the mid-nineties, Chhattisgarh has implemented the largest number of mini-grids in India covering more than 1400 off-grid habitations in the last decade. Also, the mini-grids in Chhattisgarh are based on micro solar PV plants and biomass gasifiers, while WBREDA has mostly implemented solar PV or hybrid mini-grids. Additionally, the study also focuses on mini-grids deployed by private companies such as Husk Power Systems (HPS) and Mera Gao Micro Grid Power (MGP). In order to better comprehend a comparative perspective of mini-grid variants, the report has analysed the mini-grid experiences by examining technologies adopted, policies and incentives, business models, financing and tariff structures, and community participation. The study also highlights trends in the implementation of mini-grids (both technological developments as well as institutional evolutions), and the evolving policy dynamics used to promote and incentivise both private and publicly supported mini-grid developments in India.

The research framework of the study draws from an extensive review of the literature, supplemented by field visits to selected sites, stakeholder interviews and a few focus group discussions. The study relied on a triangulation of multiple sources of data (Yin, 2003). For example, information from field visits was cross-validated by stakeholder interviews with officials/management staff working at different levels



A solar mini grid in Chhattisgarh, India. Photo credit: Gopal K Sarangi.

in the management hierarchy. While the basic structure of this report is laid by the extensive analysis of peer-reviewed literature, available grey reports and other secondary studies and reports, the key analytical contents of the report are built through explanatory case studies of mini-grid variants operating in different parts of the country. A purposive sampling technique has been applied to select the chosen case studies for analysis, keeping in consideration the need to capture the existing variations. A semi-structured interview format was administered to carry out the stakeholder interviews. Moreover, some selected telephonic discussions were also undertaken to cross-validate the findings from the field visits and stakeholder interviews. However, a major challenge faced during the study relates to inadequate data availability on the mini-grid initiatives promoted by the private enterprises, primarily because of their recent entry in the field and confidentiality of the intellectual property with respect to their business model. Nevertheless, an attempt has been made to present a comparative perspective of different mini-grid models, i.e. public, private and NGOs driven in the study.

Assessment of renewable energy-based mini-grids in India

The concept of solar PV mini-grids in India was pioneered in the 1990s in the Sunderban delta region in the state of West Bengal and in the forested region of Chhattisgarh state (then part of Madhya Pradesh state). A solar PV power plant of 25kW_p capacity was installed in 1996 by WBREDA in Kamalpur village (Sagar Island), which continues to energise the village to this day. Similarly, in Chhattisgarh, the first solar power plant was installed at a village called Lamni in Bilaspur district that is still reportedly operational. Thereafter, mini-grids connected to solar PV, biomass or small hydro, have been implemented in various states, notably Bihar, Chhattisgarh, Lakshadweep, Madhya Pradesh, Odisha, Uttar Pradesh, Uttarakhand and West Bengal.² Depending on their capacity, mini-grids provide electricity for households, small commercial activities, for community requirements such as the supply of drinking water, street lighting, vaccine refrigeration, and schools. Technically, mini-grids are preferred over other modes like solar home-lighting systems (SHSs), as mini-grids provide electricity services for lighting as well as for operating various appliances, whereas SHSs typically provide only lighting services.

While the Ministry of Power is the nodal ministry for the extension of the centralised grid electrification system in the country, it has also been instrumental to promote renewable energy-based mini-grids to electrify remote and far-off areas. The MNRE started promoting mini-grids under the off-grid electrification programmes during the late nineties and early part of 2000 to cover villages that are unlikely to be covered through grid extension. At that time, the Government of India estimated that there were around 25,000 re-

² In many villages across India, especially in Bihar, Madhya Pradesh and Uttar Pradesh, use of diesel generator (called *choti bijli*) is common. These are usually owned by individuals and used to supply power to their own homes or for powering irrigation water pumps. Often an enterprising villager works out an arrangement to provide power either to a cluster of houses or for some economic activity. The electricity is priced as flat rate (ranging between Rs 10 and Rs 15 per kWh if converted to kWh basis) and so it is availed of only by those who can afford it or who cannot afford to do without it. The diesel based mini-grids were also in operation during the 90's in many of the remote villages in hilly states of north-eastern region of India, but have been subsequently discontinued by the power departments of the respective states with increase in prices of landed diesel to such remote areas (Kumar et al. 2007)

ote villages (out of approximately 593,732 villages as per Census 2001), which will be difficult to connect through grid-supplied systems. Therefore, renewable energy-based mini-grids or stand-alone systems were considered to electrify these identified remote villages. Many of these remote villages have now been provided with renewable energy-based mini-grids or stand-alone systems such as solar home systems. Specifically, the Remote Village Electrification Programme (RVEP) and the Village Energy Security Programme (VESP) under MNRE electrified more than 12,700 remote villages and hamlets (MNRE 2013). However, with the expanding grid, some of these villages have also been recently connected despite earlier being considered inaccessible.

The two most successful models of mini-grids implemented by government agencies in India are those implemented by WBREDA and CREDA. WBREDA has set up more than twenty mini-grids based on solar power plants with an aggregated capacity of around 1 MW_p supplying stable and reliable electricity to around 10,000 households in West Bengal. CREDA, on the other hand, has electrified around 35,000 households across more than 1400 villages and hamlets with low capacity (1-6kW_p) solar mini-grids in Chhattisgarh. In addition, biomass gasifier-based mini-grids were also implemented under the VESP (in around 80 villages across different states in India) or by research institutes and NGOs such as TERI Indian Institute of Science and Development Alternatives. NTPC, the largest electricity generation company in India, also used the mini-grid model to electrify around fifteen remote un-electrified villages as part of their corporate social responsibility efforts, mainly through biomass-gasifier based technology.

The private sector has also been implementing variants of mini-grids in many states. The private companies operate mainly in villages where there are supply-constraints from the grid due to inadequate generation. Husk Power Systems (HPS), a company based in Bihar, has electrified around 300 villages and hamlets since 2007 through establishing 80 plants, benefitting nearly 200,000 people. The total aggregate generation capacity is more than 3 MW_e. In addition to the biomass gasification units, HPS is also reportedly covering un-electrified households in their operational areas through

solar DC micro-grids.³ Similar initiatives are also being undertaken by MGP, such as the setting up of solar DC micro-grids in the state of Uttar Pradesh to provide lighting services using energy efficient LED bulbs. It has reportedly connected 15,000 households spreading across 500 hamlets in Sitapur and Barabanki districts in Uttar Pradesh. Other private sector companies who have are providing electricity access in rural areas, either through solar AC mini-grids or DC micro-grids, are DESI Power, Minda Next Gen Technologies, Kuvam Energy, Gram Power, OMC power, and Gram Oorja, etc. Though SELCO India has also been working in the solar energy space for more than a decade, they have been extending the energy service mainly through customised design of solar home systems in the southern Indian state of Karnataka. A mapping of four different mini-grid models in India is captured in Table 1.

A structured discussion on various aspects of mini-grid developments in India, such as policies and regulation, technologies and sizing, business models, operation and management systems, financing, tariffs, community involvement and capacity building initiatives, is presented below.

Policies and regulation

Early attempts to electrify rural areas in India were limited in size and scope, sporadic in nature, and characterised by a lack of dedicated policies specific to rural electrification. Most rural electrification programmes were bundled with other rural development programmes and schemes, such as the Minimum Needs Programme, the Prime Minister Gramodyoy Scheme, etc. (Siddiqui and Upadhyay, 2011). Initially, mini-grids were mainly set up under the technology demonstration programme of MNRE. In 2001, with the launch of the Rural Electricity Supply Technology Mission, renewable energy-based decentralised generation technologies including mini-grids were a main focus, and for the first

³ Solar DC Micro grids are designed to generate DC electricity using one or more solar panels and are distributed over a short distance from the battery banks to the cluster of households or shops within the village. They usually supply at 24V or 48V DC to households or shops for providing lighting services for 5–7 h using LED lamps.



Solar Mini-grid in Kaylapara village – Sagar Island, Sunderban, India.

time were considered part of mainstream rural electrification. During the same period, the first focused attempt by the Government of India to look into issues related to decentralised generation, particularly in the context of off-grid electrification, also took place through the Gokak Committee. The Committee recommended that decisions between grid connection and decentralised generation, especially mini-grids, should consider the technical, managerial and economic issues. Considering the higher cost in setting up mini-grids, the Committee observed that the totality of the socio-economic benefits accruing to various stakeholders should be taken into consideration while evaluating the feasibility of mini-grids in remote areas.

Thereafter, the Electricity Act of 2003 was enacted with the overall objective of developing the electricity industry and providing electricity access to all areas. It envisaged a two-pronged approach for improving rural electricity access: a national policy for rural electrification to extend the reach of grid-connected supply, including the enlistment of local initiatives in bulk purchases and rural electricity distribution; and a National Electricity Policy to encourage additional capacity addition by way of stand-alone systems, including those based on renewable sources of energy (Figure 2). The Act also opened the door to renewable ener-

Figure 2: Options for Rural Electrification under the Electricity Act 2003

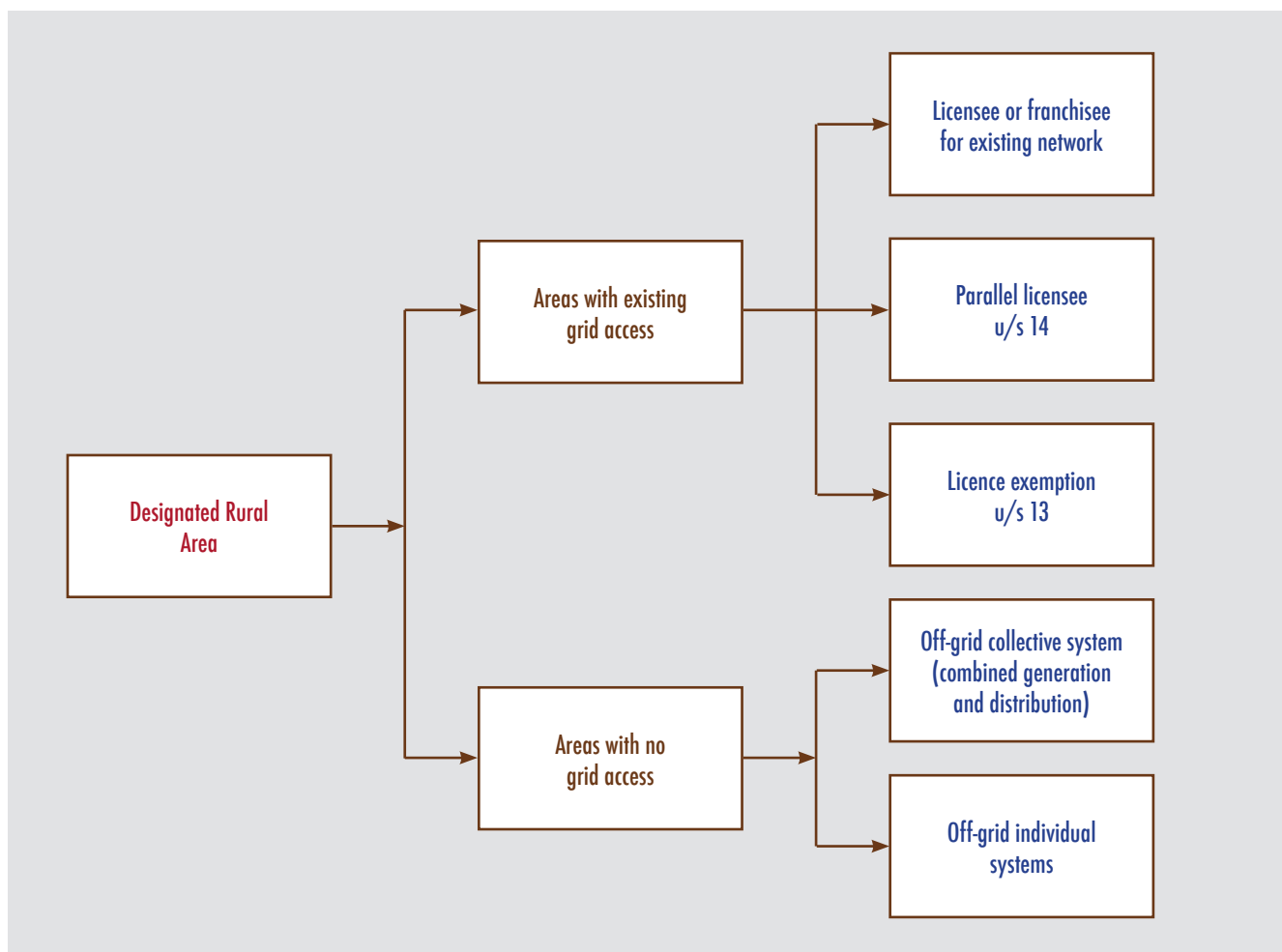

gy-based off-grid generation to a much greater extent than before. Under Section 2(63), the Act specifies distributed generation through stand-alone energy systems as a model for rural electrification in addition to grid extension. Section 14 further exempted a person intending to “generate and distribute electricity” in a rural area, notified by the State Government, from obtaining any license from a regulator. However, Section 53 of the same Act also mandated that such persons shall have to conform to the provisions relating to safety and electricity supply from the appropriate authority.

The Act was followed up by the launch of the National Electricity Policy in 2005 and the Rural Electrification Policy in 2006, which emphasised that wherever grid-based elec-

trification is not feasible, decentralised distributed generation (DDG) together with a local distribution network, i.e. mini-grids, would be provided. The policy development also made inclusion of DDG projects a part of the Rajiv Gandhi Grameen Vidyutikaran Yojana (RGGVY), which was a big step in mainstreaming off-grid electrification technologies within the ambit of the national rural electrification strategy. In addition, the two policies also enshrine that the benefits of subsidies should be passed on to the end consumers. The Rural Electrification Policy also provisions that the retail tariffs on electricity supply set by providers exempt under Section 14 would be based on mutual agreement between such persons and the consumers.

Table 1. A comparative assessment of mini-grid models in India

Parameter		WBREDA	CREDA	Husk Power System	Mera Gao Power
Area of operation (Province(s))		Sunderban	Chhattisgarh	Bihar	Uttar Pradesh
Technology		Solar PV	Solar PV	Biomass Gasification	Solar PV
Typology		Publicly supported	Publicly supported	Private	Private
First plant commissioned		1996	2004	2008	2011
Achievement		22 mini-grids serving about 10,000 households	1439 villages & hamlets serving about 35,000 households	80 villages serving 25,000 households	500 hamlets, serving around 15,000 households
Average size of power plant		25-100kWp	1-6kWp	25-100kWe	120-800Wp
O & M structure		Contracted out through Annual Maintenance Contract (AMC)	Contracted out through AMC using cluster-based approach	Cluster-based approach with O&M done by the company	Cluster-based approach with O&M done by the company
Energy provision		2-5 light points x 11W CFL and fan point	2x11W CFLs	2x15W CFL & plug point	2 light points and facility for mobile phone charging totalling 4W
Energy application		Lighting, fan, TV, and some productive activities	Mostly for lighting, also for running fan and TV, etc.	Lighting, fan, mobile phone charging, etc.	Lighting and mobile phone charging
Supply duration (hours/day)		5-6	5-6	6-8	7
Financing	Tariffs	US\$2.5 for 120W and US\$1.5 for 60W per month	US50¢ per month	US\$2 to 3 per month	US50¢ per week
	Subsidy received	Yes	Yes	Yes	Yes

Source: TERI compilation, 2013

Technical features and capacity

Mini-grids vary in technical features, with a typical capacity being between $1kW_p$ and $200kW_p$, with different states adopting different capacities and models depending on their local requirements and conditions. While mini-grids in Chhattisgarh are based on micro solar PV plants ($<7kW_p$ capacity) and biomass gasifiers plants ($\sim 30kW_g$), the solar PV-based mini-grids in the Sunderbans are in the range of $25-150kW_p$ (Palit, 2013). These mini-grids have been using state-of-the-art inverters and storage systems of the time to ensure a long life and reliable field performance. However, over time, changes have been introduced to the capacities and technological configurations pursuant to technological advancements and communities' changing requirements. Until 2000, Solar PV alternating current mini-grids in the capacity range of $25-26kW_p$ were implemented by WBREDA. Larger capacity schemes were not commissioned at

that time largely due to a lack of acceptance of the concept and technological hindrances. Later, with technological advancements and wider demand for such systems, larger capacity ($>100kW_p$) mini-grids were deployed in the Sunderbans region. Furthermore, to maximise the load factor, WBREDA established the plants near the load centre. To meet additional power demand, hybrid-generating systems have been installed by combining solar plants with other renewable sources such as small wind-powered generators and biomass gasifiers. This hybridisation has helped WBREDA to optimise the various renewable energy technologies depending on their availability and local weather conditions. In Chhattisgarh, the mini-grid capacity has been standardised for ease of operation and maintenance, viz. 1, 2, 3, 4, 5 and $6kW_p$ being implemented with two ratings of inverters. While the systems with an installed capacity of $1-3kW_p$ have a battery-bank of 48V and inverter rating of

3kVA, the systems with 4-6kW_p installed capacity have 96V battery-bank and inverter rating of 5kVA.

Moreover, the battery bank in most power plants in Chhattisgarh was found to last for 8-10 years, which is much higher than the usual battery life of 4-5 years prevailing in most other states such as in the Sunderbans region where solar mini-grids have been implemented extensively (Ulsrud et al., 2011). In case of the Sunderbans, the batteries have given many extra challenges for the whole operation and have sustained the solar mini-grids. Because of the battery problems, the hours of supply to the customers after a while became significantly shorter than when the batteries were new. Moreover, the practice among customers of drawing more electricity than was meant by the system designers increased the pressure on the batteries and exacerbated the problem. While currently available battery management systems can address the problem of overdrawing, the degree to which such systems can be integrated with the system are limited by the issue of cost.

Biomass gasifier-based independent mini-grids implemented under VESP and other initiatives, such as the distributed generation programme of NTPC and private initiatives such as Husk Power Systems and DESI Power Systems, are mostly connected to 10-50kW_e generators. Since sustainable fuel supply is critical to biomass technology, projects implemented under VESP emphasise the need for energy plantations in the vicinity of the power plants. Husk Power Systems and DESI Power has diversified their source of fuel by including other biomass resources like wheat husks, elephant grass, mustard stems, corn cobs, etc., with rice husks to ensure a year-round source of fuel. In the case of HPS, a typical plant with capacity of 33kW_e supplies electricity to about 2-4 villages (300-400 households) within a radius of 1.5km.

Lately, private mini-grid developers and village-level entrepreneurs are also setting up low voltage solar DC micro-grids, either on their own or under different programmes such as the Lighting a Billion Lives initiative by TERI. These micro-grids generate DC electricity from solar panels and the power is distributed over a short distance from the battery banks to clusters of between 20 and 100 households. They usually supply at 12V or 24V DC for providing lighting services for 5-7 hours using LED lamps of 2-6 watts per household (2-3 light points per household) and power for mobile phone charging facilities. DC micro-grids implemented by MGP and TERI have central storage systems and connect

around 20-50 households, whereas HPS and Kuvam Energy are reportedly implementing micro-grids using decentralised storage batteries in the consumers' households connected to centralised solar PV systems.

Additionally, smart controller and pre-paid metering systems are being used in many new projects to check overloading as well as theft of electricity. For example, HPS has introduced smart meters in all their mini-grid systems. It claims to have innovated the world's cheapest pre-paid meters to put a check on the illegal consumption of electricity. Similar efforts have also been taken by developing systems to monitor remotely the performance of the plant, introducing low-cost management and information systems, etc. Another start-up company called Gram Power has developed a smart stackable battery called MPower, which is a modular power source comprising of a high-density lithium ion battery and intelligent power conditioning circuitry. The MPower is designed in such a way that its charging is locked to the micro-grid, i.e., no other power source but Gram Power's electricity supply is able to charge the MPower. This avoids misuse of the device and ensures revenues for the local entrepreneur.

Service delivery models

The operational artefacts of mini-grids reveal that they operate under various delivery models. Most of the publicly supported mini-grids in India are structured around community-based models, albeit with different names, such as Village Energy Committee (VEC), Village Development Committee (VDC) and Rural Electricity Co-operatives (REC) (Figure 3). A majority of publicly supported mini-grid projects promoted by MNRE, such as VESP and RVEP, follow the VEC structure with some variations. Here, the VEC or the REC play the pivotal role as a power producer, distributor and supplier of electricity. The service delivery approach of the model involves the formation of a VEC by the Project Implementing Agency (PIA) – usually the state renewable energy development agency or a non-governmental organisation (NGO) – with representations from villagers and the local governing bodies (known as *Gram Panchayat*). The VEC usually consists of nine to 13 members, with 50 percent representation from women members and elected village *Panchayat* members being ex-officio members of the VEC. The PIA sets up the energy production systems and hands over the facility to the VEC for day-to-day operation and management. The VEC thus acts as custodian of the energy production system and is responsible for its operation and

management. The electricity generated is distributed to the community through local mini-grids.

In line with the provisions of the Rural Electrification Policy, often the tariff is set by the PIA in consultation with the VEC. As the capital cost is almost entirely subsidised, the tariff is set such that the revenue can take care of the fuel, operation and maintenance costs including remuneration of the system operator. The VEC is also responsible for arranging the fuel (in the case of biomass or bio-fuel projects) as a contribution from the project beneficiaries on a rotational basis, through purchase from agents such as self-help groups, or through raising energy plantations. User charges are collected by the VEC to meet the operational expenses, and they also manage the accounts related to the project.

CREDA and WBREDA, however, have developed their own service delivery mechanisms, directly taking care of the O&M through a multi-tier system of maintenance. In the case of the Sunderbans region, WBREDA has facilitated the formation of the Cooperative Society or Beneficiary Committee. Similar to the VEC, these groups consist of mini-grid consumers. The model is also structured similar to the VEC model, though some specific aspects differ (Figure 4). The responsibilities of the cooperative or beneficiary committee include selection of consumers, planning for the distribution networks, tariff-setting in consultation with WBREDA, revenue collection from consumers and passing them on to WBREDA, and consumer grievance redress. For all the projects implemented by WBREDA, the capital cost for the hardware is borne entirely from the funds available from MNRE programmes and provincial government. Furthermore, the local government also arranged the land for the power plant. Thus, the tariff structures have been designed only to cover operational and maintenance costs and some part of the battery replacement cost.

The rural (*Grameen*) banks operating in the area act as intermediaries between the cooperative and individual consumers to collect the bills. Another innovative practice in the Sunderbans model is the separation of revenue collection from plant operation by assigning these activities to two different entities. Therefore, plant operation does not get affected because of problems in revenue collection. The community model for solar PV projects has been largely successful, unlike other technologies such as biomass gasifiers, primarily due to the easy management of solar technologies (Palit and Chaurey, 2011). Yet it is observed from the literature that there exist challenges in mobilising addi-

tional revenue to meet expenses such as the replacement of batteries, large-scale maintenance of plants, etc. Based on a case study of solar power plants in the Sunderbans, Shrank (2008) found that the community management system did not create adequate incentives for maximizing profit at each power plant, thus creating problems in covering the costs of power supply.

On the other hand, CREDA developed their own service delivery model, (Figure 5) placing more emphasis on managing projects following a 'top-down' mode. While CREDA also forms VECs that are assigned a limited role, it retains local oversight and acts as a grievance redress forum. The VEC is not held responsible for technical operation and maintenance. CREDA directly takes care of the operation and maintenance through a three-tier system of maintenance framework to ensure trouble-free working of the mini-grid systems. CREDA selects an operator from the village for switching the systems on and off, monthly cleaning of modules, and to report any faults to the cluster technician. In addition, CREDA enters into a contract with an operation and maintenance contractor, who appoints a cluster technician for every 10 to 15 villages. Each technician earns INR4,000 (US\$80) and if desired, a motorbike is provided, which is redeemed in instalments of INR1,000 (US\$20) per month. The village-level operator is also paid a fixed monthly remuneration. In addition, CREDA officials monitor all the installations through monthly reports and replace damaged equipment wherever required. For example, an adequate supply of replacement lamps is kept in stock with each cluster technician to handle lamp burnouts.

In addition to the aforementioned community-led mini-grid models, the projects implemented by the private sector follow a commercial approach and are purely demand-driven (Refer to Box 1, Figure 6). For instance, MGP is implementing solar DC micro-grids using a micro-utility approach where they design, install, operate, maintain and provide the service to consumers in exchange for a weekly fee. HPS has developed a franchisee-based business model for setting up mini-grids. HPS follows the BOOM (built, own, operate and maintain), BOM (built, own, maintain) and BM (built and maintain) models for providing electricity services. To some extent, these private initiatives also involve local stakeholders in helping with social organisation and achieving better community responses. Cluster managers appointed to manage a number of plants (around five to 10) in a cluster often act as co-ordinators between plant-level activities and the decisions taken at the top hierarchy of the company.

Figure 3: The VEC model (Source: TERI Compilation)

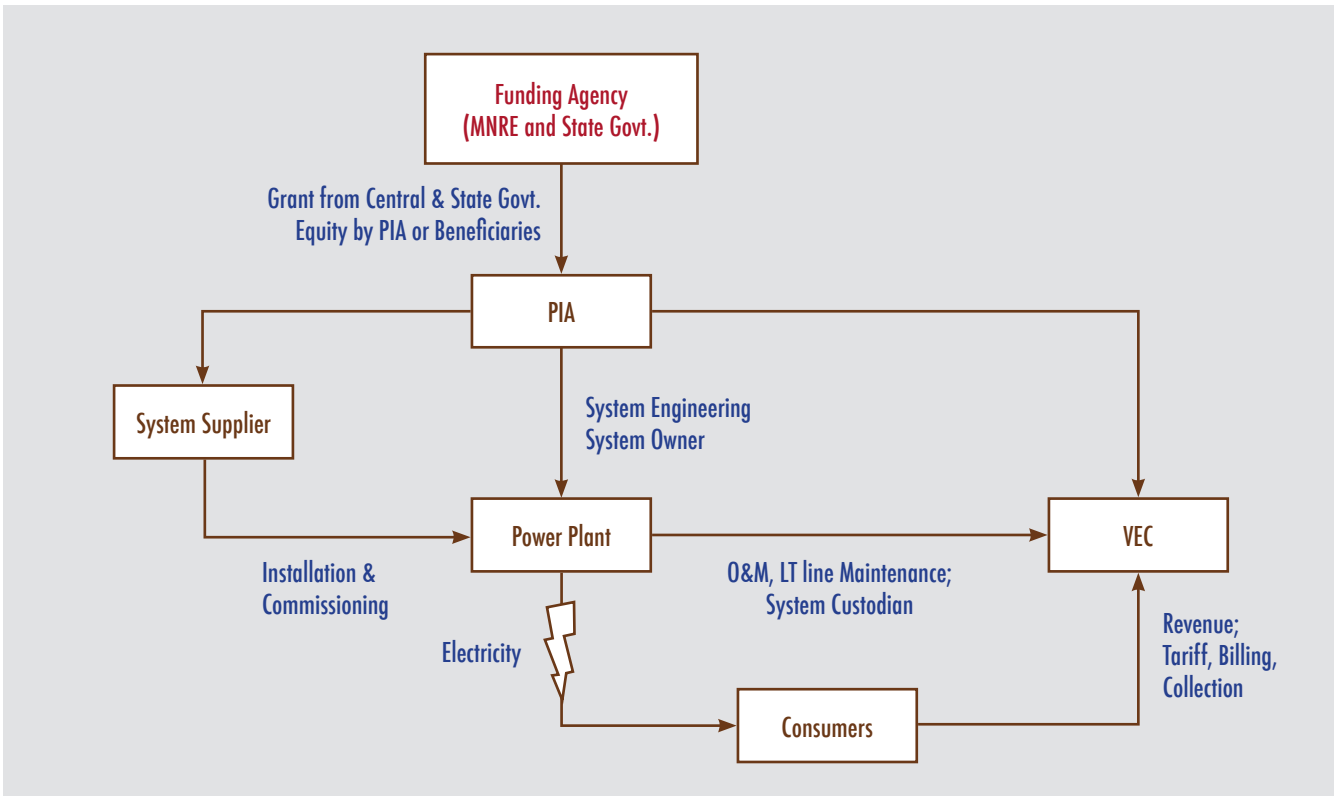

Figure 4: The WBREDA mini-grid model (Source: TERI Compilation)

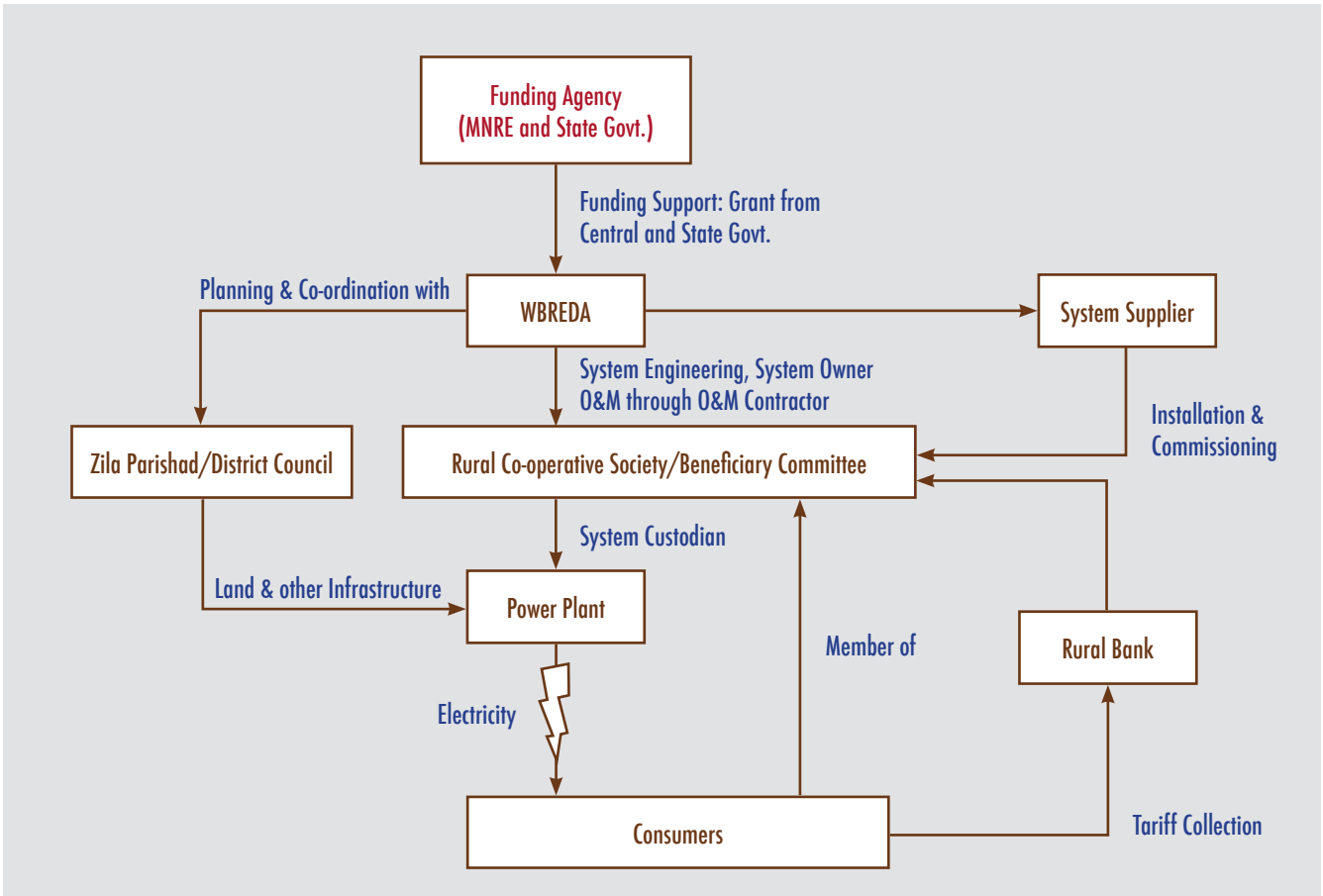

Figure 5: The CREDA mini-grid model (Source: TERI Compilation)

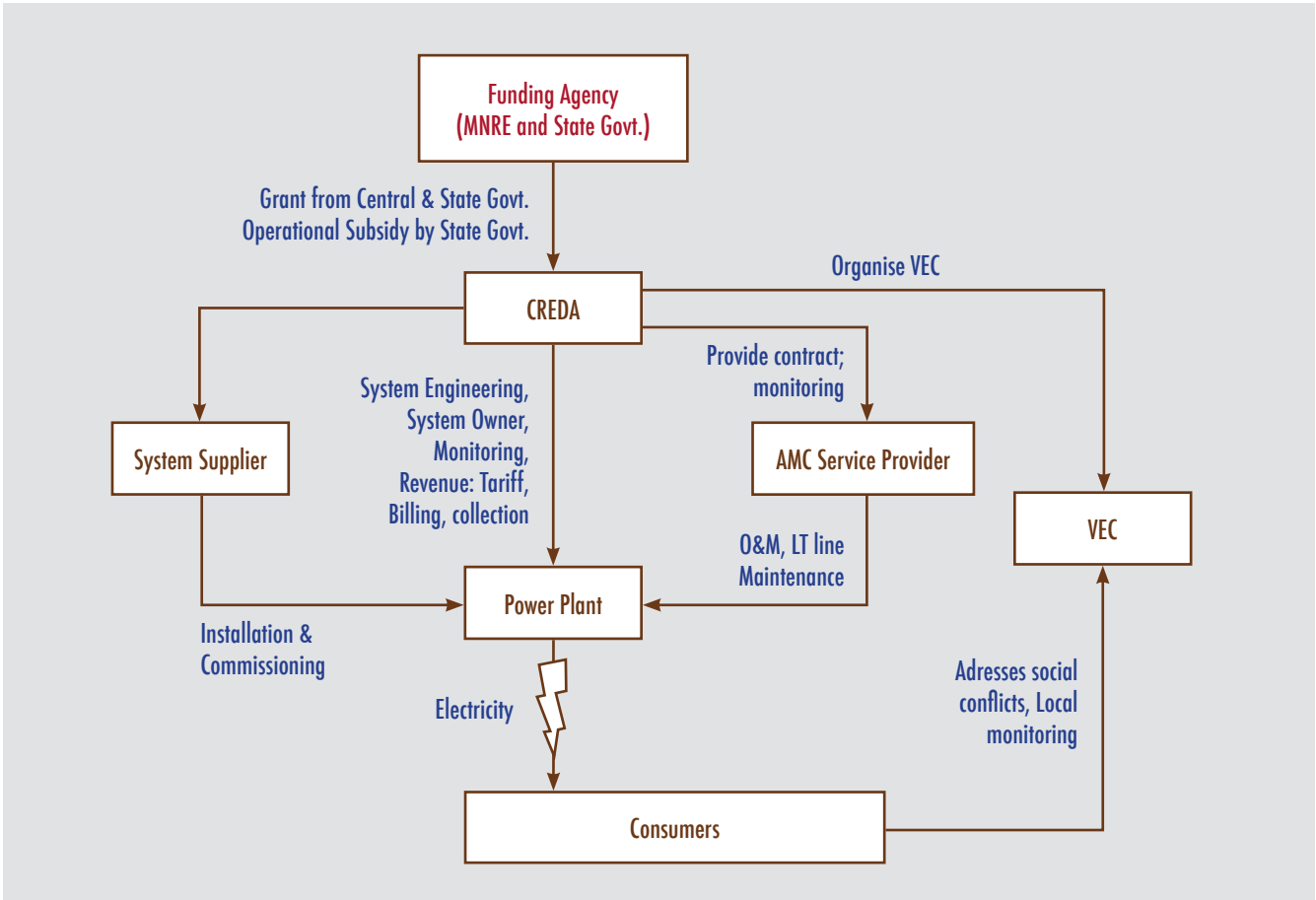
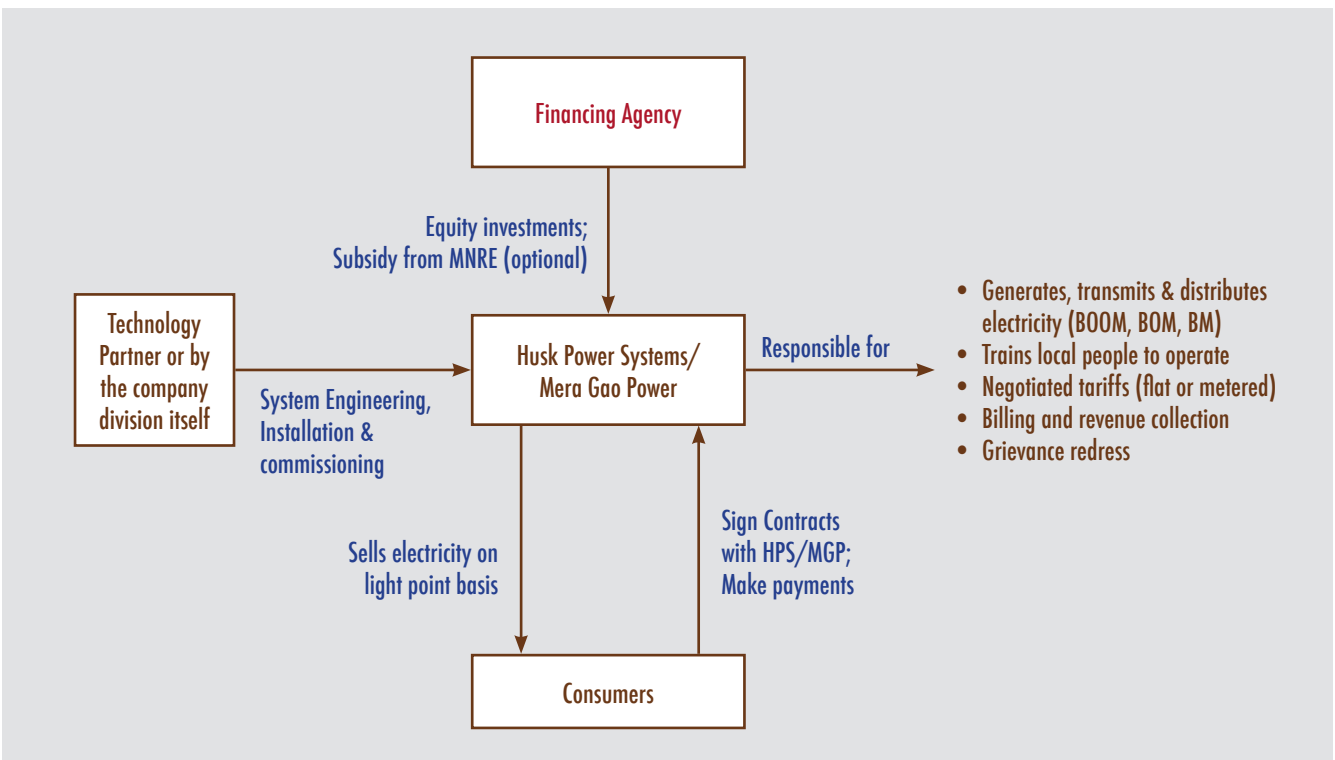

Figure 6: Mini-grid model of typical private sector company (Source: TERI Compilation)



Box 1: Private sector-led models providing electricity access – Some examples

Interesting variants of business models have been promoted and implemented by private companies. Husk Power System (HPS) has evolved a set of business models to cater to the varying needs of the local people with emphasis on creation of local entrepreneurship, as well as to expand its business units to other parts of the country and globe. There is a BOOM (Built-Owned-Operated-Maintained) model, where HPS is engaged in setting up plants, procurement of feedstock, and management of affairs, in the entire chain of project development. The BOM (Built-Operate-Maintain) model splits up the activities in such a way so that the plant is built, owned and managed by HPS, whereas operation is left to local entrepreneurs. Still the other variant is called the BM (Built and Maintain) model, where the plant is built and maintained by HPS, but owned and operated by local entrepreneur. These models have evolved and been applied from HPS's past learning and the desire to expand it to other parts of the country and globe.

Another interesting type of business model being pioneered by OMC Power, a new entrant in the mini-grids sector and advocated by donor agencies like the World Bank, is known as the A-B-C model, where three different groups of customers, i.e. Anchor, Business groups and Community members (A-B-C), are identified for energy provisioning. Within the three groups, anchor load is predictable and offers a guaranteed source of revenue for the project developer, whereas business group and community members are usual customers for the project. For OMC Power, the main anchor customers are telecom towers. In this regard, OMC has signed an agreement with Bharati Infratel to electrify its telecom towers through the provision of micro-power for the next 10 years. For commercial establishments and other community users, OMC Power has devised a concept called 'micro-power business-in-a-box' where community entrepreneurs are engaged in the village electrification process. Micro-power from OMC ranges from a 1.2kW load to 3.6 kW and beyond. For rural consumers, it has a pre-paid system based on subscription, where a rural consumer is charged a monthly rental of US\$2 per month. The tariff is set by OMC Power based on a commercial approach. OMC Power also has developed a structured power management system, which ensures the optimal use of energy through well-designed energy efficiency systems.

Gram Power, another innovative private mini-grid developer, has evolved a business model called 'pay as you go' to electrify remote rural villages in India through the use of advanced technologies. Provision of electricity is made on demand. A pre-paid credit model has been evolved not only to electrify villages but also to create village-level entrepreneurs as well. Local entrepreneurs purchase pre-paid bulk energy credits from the Gram Power and wirelessly transfer the pre-paid recharge into consumers' meter, again on a pre-paid basis from the consumers. The meter also has the provision of indicating the quantum of load that can operate for certain hours. Pre-paid meters charge consumers on an hourly basis. For instance, around US\$1 could purchase 200 hours of CFL lighting or 50 hours of fan operation. Local entrepreneurs earn around 10 percent on every power sale.

Mera Gao Power is again another example of an innovative business venture by the private sector providing low-cost micro-grid power solutions to rural India. The company has been able to make it a commercially viable business entity, largely due to low capital and operational costs, with a projected return of more than 30 percent at a repayment period of less than three years. The emphasis of Mera Gao Power is to provide service-specific micro-grids designed to meet the lighting and mobile charging requirements of rural people. A village-level electrician carries out activities related to connection and disconnection. Local women's groups are engaged in payment collection. For household electrification, LED based lights and plug points for mobile charging are provided.

Source: Interviews with respective company officials and field visits.

Financing

Most of the mini-grids in India have been financed using the publicly provided capital subsidies by MNRE. All the publicly supported programmes, like RVEP, VESP, DDG and the off-grid component of the Jawaharlal Nehru National Solar Mission (JNNSM) provide varying levels and forms of subsidies for the projects. In the majority of cases, subsidies cover up to 90 percent of the project cost (up to a predefined maximum per household), with the balance amount mobilised through other sources such as provincial government funds, contributions from the local Member of Parliament or Legislatures, the corporate sector as part of their social responsibilities, or from community contributions. The consumers own the household electrical wiring and appliances and only pay for the services they use. However, in the case of below-poverty-line households, subsidy funds also take care of wirings and service connections. JNNSM provides capital subsidies for mini-grids either to meet unmet community demand or electrification of un-electrified rural areas. On the other hand, the DDG programme of RGGVY considers technology with the lowest marginal cost and extends the subsidy of 90 percent of the project cost and some operational subsidies.

Historically, MNRE programmes have been providing subsidies to meet the capital cost of the projects. However, of late, it was realised from the experiences of different programmes that some form of O&M subsidies may be essential to sustain the project operations over a long period, particularly in the case of

extremely remote areas with a poor ability to pay. Therefore, recent programmes such as DDG programme of Ministry of Power has the provision of not only subsidising the capital cost of the project, but also in providing some operational costs of up to five years of project operation. Apart from publicly supported projects, the private operators also benefit from the subsidies as per the norms of the different schemes. The details of the subsidies prevailing under different programmes are provided in Table 2.

Private mini-grid promoters and developers largely have tapped developmental bank loans or have mobilised finances from venture capital funds. In addition, in many instances, private mini-grid developers have also raised funds from various donor agencies (e.g. MGP, Azure Power) CSR financing (e.g. Gram Power, Sun Edison), prize money (HPS and Gram Power) and private equity financing, etc. Recently, mini-grid developers also have started mobilising additional finances from unconventional sources like carbon financing, though to a limited extent. For instance, HPS has been developing a Programme of Activities for clean development mechanisms to receive carbon credits. The major challenge to mobilise finance through this route is the scaling-up of projects. As decentralised renewable systems replace very small amounts of kerosene or diesel, the challenge is to bundle a sufficient number of projects operating in a region/locality to make it viable for carbon financing. Although there exists reasonable potential for carbon-financing, current statistics point to the very limited number of mini-grid projects in the region having received carbon benefits.

Table 2. Targets, ownership structures & subsidies for renewable-based mini-grids in India

Scheme	Time frame	Target under the scheme	Ownership	Finance	
				Subsidy vehicle	Central Financial Assistance
RVEP	2001 onwards	Electrification of census villages and hamlets near electrified villages that are not likely to receive grid connectivity	VEC/Community	Capital Subsidy subject to upper limits	90% of the costs of various renewable energy devices/systems subject to pre-specified maximum subsidy <i>Maximum CFA per household is US\$300⁴</i>
VESP	2004-09	1,000 villages to be electrified within the current 5-year plan	VEC/Community	Capital subsidy Operational subsidy for first 2 years	90% of the total project cost <i>Maximum CFA per household is US\$333</i> 10% of the total project cost
DDG under RGGVY	2009 onwards	N/A	State Government	Capital subsidy Operational subsidy for 5 years	90% of the total project cost 10% of the total project cost
JNNSM (Off-grid component)	2010 -2022	20 million decentralised solar PV systems	Local bodies/State Government/	Capital subsidy	US\$1.5/W _p (with battery storage) US\$1.17/W _p (without battery storage)

Source: TERI compilation, 2013.

4 US\$1 = INR 60

Tariffs

While the above section discussed the crucial issue of project financing, a related and pertinent aspect of project sustainability rests on the designing of appropriate tariffs. While there exists some degree of uniformity in the quantum of subsidies provided under publicly supported programmes in India, a visible difference could be singled out as far as the tariff structures are concerned for both publicly supported as well as privately implemented mini-grids. This is primarily due to the fact that decisions on tariffs are outside the purview of the current regulatory regime, and are determined through a negotiated process taking into consideration the prevailing socio-economic aspects of a given area.

The tariff for publicly-funded projects such as those implemented by CREDA and WBREDA considers the operation and maintenance cost, including the salary of the operators and other related aspects such as the consumers' ability to pay. The tariff is not necessarily determined based on economic cost of generation and distribution. For instance, Ulsrud et al. (2011) observe that WBREDA's designing of tariffs for mini-grids in the Sunderban has considered several factors such as government funding, the customer base, income distribution, availability of anchor customers, acceptability of measures to put a ceiling on consumption, and equity issues in finding the right balance between affordability and the economic cost of electricity generation. Interestingly, this institutional set-up, with an emphasis on local involvement in the setting of tariffs, appears to have worked well in the Sunderbans or in areas where people are better off. Additionally, it is also observed from various studies conducted by TERI that in areas with a predominantly ultra-poor population, consumers tend to pay during the initial months of the project operation and then start defaulting as electricity is given less priority compared to other basic needs of life such as food, clothing and health (Palit et al., 2011).

In the case of publicly funded projects implemented by government agencies, tariffs for mini-grid consumers are mostly based on flat rates as per light point, per month, per consumer. This fixed tariff is much easier to administer than a system of metered tariffs, primarily because of low electricity consumption. The number of light points and time of supply are also usually fixed. Our studied cases reveal that in the case of WBREDA, the cost of a service connection together with a fixed initial security deposit is in the range of US\$17-25, and the tariff is about US\$2.08 per month for 100W of connected load. However, the energy service charges differ based on the connected loads. For instance, a monthly lump

sum energy service charge of around US\$2.2 is levied for 120W of connected load and US\$1.25 per month for 60W. Consumers are free to apply for more than one connection depending on their requirements and ability to pay.

On the other hand, CREDA levies a connection charge of US\$1.7 for below-poverty line families, and US\$3.3 in other cases. The tariff is a flat US\$0.50 per consumer for all households having two light points connected to a mini-grid. However, almost 85 percent of this amount is paid by the Chhattisgarh State government in line with their state policy for subsidising the tariff for one light point for all poor consumers (both grid-connected as well as mini-grid), and beneficiaries pay the balance amount. A disadvantage of this flat tariff system, however, is overloading by some households (connecting additional electrical points to those authorised), which puts extra pressure on the entire system. It was learnt from our field studies in the Sunderbans that better economic conditions and rising aspirations led to increasing use of various electrical appliances, thereby putting additional pressure on the existing systems. However, this is not always the case. For instance in Chhattisgarh, given the low economic standards of the beneficiaries, additional demand was found to be very limited.

The privately funded projects consider the economic cost of generation for project viability and have also developed their own approaches for the financial sustainability of their projects. For instance, HPS and Gram Power have formulated guidelines whereby installation of a power plant requires the presence of a minimum number of consumers who are ready to buy electricity (approximately 400 in the case of HPS and a minimum of 20 households in the case of Gram Power). HPS charges a nominal installation fee as well as a basic connection fee of around US\$2-3 per month for two-15W CFL and a plug point for mobile charging for domestic consumers. Tariffs charged for commercial use are a little higher than the domestic tariffs so that the poor consumers can be cross-subsidised⁵ and the project is revenue sustainable. In the case of MGP, there are connection fees as well as monthly charges. MGP charges connection fees of about US\$0.80 and there is a weekly charge of about US\$0.40. For OMC Power, a pre-paid system based on subscription decides the tariff. OMC has devised a system called 'The OMC Power Box,' a rechargeable carry-home unit for portable power. Consumers have to pay in advance to access these systems

5 Cross subsidisation is the practice of charging higher prices to one group of consumers in order to subsidise lower prices for another group.

and accordingly must reveal the amount of electricity they want to consume in advance. Tariffs depend on the amount of power consumers want to consume, and accordingly the OMC Power Box is charged to deliver that quantity. Such a design helps the entrepreneur to address payment defaults. The usual monthly tariff is US\$2. In order to deal with the uncertainty in revenue collection, OMC Power has contracted some anchor consumers, such as telecom towers, where a predictable source of revenue is ensured.

Operation and management

Operation and management (O&M) is the critical component of the mini-grid models, and has thus received priority in all the studied cases. Innovative O&M processes have been developed and operationalised by WBREDA and CREDA and have effectively been integrated to ensure optimum functionality of the deployed projects. While the O&M of mini-grids has been traditionally carried out by the plant operator and VEC, recent experiences show new ways of conducting this service. It was observed during field surveys that WBREDA and CREDA engaged qualified technicians as third parties for the local O&M of the mini-grid projects. The technician is either from the original equipment supplier, or the task is contracted out to local service providers who engage trained personnel for the job.

For instance, in the case of the Sunderbans, comprehensive annual maintenance contracts are signed for the management of plant O&M and low tension line maintenance. The contractor for plant maintenance has to provide trained and qualified operator(s) for the day-to-day O&M works. The maintenance contract is usually given to a local contractor, which builds local entrepreneurship and at the same time ensures a quick and reliable service. The companies are bound by the contract to resolve the problem within seventy-two hours of the problem being reported to them. Another management innovation experimented by WBREDA, which contributed to the sustainability of the model, is the clear fragmentation of responsibilities between operator and revenue collector. The operator, being appointed by the service contractor, focuses on the operation and maintenance of the project, while the responsibility of revenue collection rests with a different person appointed by the village community. Therefore, any shortfall in the revenue collection in a particular month does not affect the operation of the plant. In contrast, one of the reasons for the limited success of mini-grids implemented under VESP is because the sy-

stem operator also acted as revenue collector, and in the case of inadequate collection, the operators were paid less or not at all. This made them lose interest in operating the systems (Palit et al., 2011).

CREDA went a step further and developed a cluster-based approach for maintenance to reduce the transaction costs associated with the operation and management of projects, since their power plants are located in very remote areas in the state. It is called the “cluster-based service delivery model” or “GOLD” (Group the partners, Organise their skills, Allocate load in villages, Deliver service) model, where the installation is steered by CREDA and the O&M of the plants is undertaken through a three-tier maintenance setup. In general, one cluster consists of 10-15 villages and/or hamlets. Each cluster has one cluster technician, one assistant to the master technician, and an operator and VEC for each mini-grid. The plant operator looks into the routine maintenance of plant, such as cleaning modules, battery checking, wiring/PDN checks, etc. The cluster technician is responsible for visiting each village once a month to execute preventive maintenance and is further responsible for resolving any breakdowns. The cluster approach and dedicated contracts for post-installation maintenance have ensured better service and hence more sustainable operation.

Interestingly, private mini-grid developers have developed innovative ways of dealing with the O&M of projects by taking into consideration the confronted challenges. Husk Power System has developed a similar approach to the CREDA model. For each plant, an individual plant manager is appointed, preferably from the same village. At a higher level, (i.e. cluster level constituting of 5-6 plants), a cluster manager is appointed. It is the responsibility of the individual plant manager to send daily reports to the cluster manager. Thereafter, cluster managers provide the information regarding plant operation and management to regional managers. Finally, regional managers report to the central office. Because of the rigorous monitoring and management systems, plants are reportedly achieving above 90 percent availability. Of late, the most advanced technological systems have been employed by HPS, like remote real time monitoring systems, to keep tabs on the performance of plants in real time. Given that MGP's business is dependent on long-term revenue flow, they ensure the long-term operation of each micro-grid they build and operate. They maintain a customer service number to track performance problems. Further, to keep systems running, MGP has a

team of maintenance electricians to respond to each performance problem within 24 hours.

Community participation and capacity building

Community participation is widely acknowledged as an essential ingredient for ensuring equity and the sustainability of any decentralised electrification. Local participation in the form of village energy committees or electricity cooperatives has reportedly contributed to better project management, though to varying degrees. The level of engagement of communities in the operation and management of projects differ significantly. Often, rural communities get engaged in the project development from the very inception of the project planning until the commissioning and operation of projects. In some other cases, participation seems to be passive in nature, limited to the upkeep of the project operation and management.

Capacity building, an important ingredient in the successful operation of mini-grid projects, has been prioritised in all the studied cases. In the policy sphere also, capacity building is recognised as vital for the success of these projects. For instance, the Decentralised Distributed Generation programme of RGGVY has a clear specification that it is the responsibility of the project developer to provide the necessary training/capacity-building to villagers for running the project. Similarly, the off-grid component of JNNSM focuses on sensitising banks to promoting small-scale solar-based interventions. Experiences from the field reveal that the levels of capacity needs differ for different stakeholders engaged in the project operation and management. Various training modules have been organised from time to time by project implementation agencies/project developers/state renewable energy development agencies through a range of training programmes and workshops, etc., catering to the needs and requirements of different stakeholders engaged in project operation and management. It was found that general awareness programmes are periodically organised primarily for the beneficiaries of the projects. Similarly, plant operators and/or technicians are trained on the technical aspects of project operation and management, and local community groups/NGOs are offered a basic level of training to look into every aspect of project management.

To cite some specific examples of such capacity enhancing efforts undertaken in the country, it is worth highlighting

the case of the “Installers Certification Programme” by CREDA, which is designed for personnel who are specifically assigned to carry out the installation and commissioning of projects. CREDA also provides refresher-training programmes every six months for technicians, operators and VEC members. WBREDA occasionally conducts training workshops and invites solar experts to share knowledge on the available techniques and research and development of solar PV technologies for technicians and operators of mini-grid projects. While most of the VESP projects have not been performing well, it has been observed that innovations adopted by selected project implementing agencies for operator capacity-building have improved project performance in some projects (Palit, 2011). In some cases, project proponents conducted capacity-building for the system operators at three stages – before, during and after installation – through a process of handholding support. CREDA involved a local gasifier manufacturer to place trained technicians in the villages for a period of three months from the commissioning date to support and provide handholding to the local operators. Such innovative practices raised the confidence of the operators to continuously run the system and achieve better performance. This in turn also helped to build confidence among communities, facilitating a willingness to pay for regular and reliable electricity.

Private mini-grid promoters also have considered capacity enhancements as one of the key ingredients of success. Husk Power Systems has instituted a University (known as Husk Power University) to impart technical know-how to local rural people with limited formal education. This approach consists of training rural people on issues of plant operation, maintenance and electrical aspects, with adequate attention to the cultural milieu and logistical requirements of rural settings.

While the process of training programmes tends to enhance the skill sets of many rural youths engaged in the projects, they also increase their prospects of employability in other allied sectors. It was observed from our field discussion with project developers that in many cases, plant technicians and project operators leave the project after a few months/years and are engaged in some other activities due to their experience in the sector and technical skills through training. This also requires scheduling training programmes in regular intervals to address the scarcity of skilled workers in the sector.

Challenges in dissemination of mini-grids

Despite visible progress being made in multiple aspects of mini-grid development in India, several barriers continue to derail the speed and magnitude of mini- and micro-grid deployments in the country (Chaurey et al., 2004; Radulovic, 2005). It merits mentioning some of the major hindrances obstructing the growth of renewable energy centric mini-grid deployment in the country.

Policy-level impediments include the lack of a long-term vision for the sector. The current policy regime governing the off-grid sector appears to be myopic and lacking in foresight, and thereby generates policy-level uncertainties for prospective investors and project developers. For example, current policy frameworks do not clearly discuss interconnection standards in feeding excess energy from a local mini-grid system to the conventional grid at the lower voltage level (in areas where a conventional low-voltage grid exists). This has become very important in the context of the DDG guidelines under RGGVY, which specifies that infrastructure should be grid-compatible so that the investment will continue to be useful once a village is connected to the grid. However, in reality small DDG plants and poor rural infrastructure cast serious doubts on such compatibility. Further, the 2013 regulations of the Central Electricity Authority (offering technical standards for connectivity of the distributed generation resources) lack clarity on the connection of small distributed generation systems with the distribution grid network.

Further, under the current policy and regulatory regime, the determination of tariffs is left out from the regulatory purview. Therefore, retail tariffs are primarily determined through negotiation between the consumers and electricity service providers. Given the nature of these projects, and geographical disadvantages associated with these project locations, per unit capital costs and O&M costs come out to be relatively high compared to the conventional electricity systems. This, when coupled with low paying consumers, generates problems related to revenue generation and thus undermines the financial sustainability of projects. This could have, at least partially, been avoided through the provision of cross-subsidies. However, under the current legal and

regulatory system, benefits of cross-subsidisation (between urban, industrial and rural consumers) are only confined to the grid-supplied consumers and cannot be extended to the consumers of off-grid systems.

Another related roadblock to the up-scaling and proliferation of mini-grids in India is the lack of adequate investment in the sector. Most companies active in mini-grid/off-grid distribution are not able to gain sufficient capital to expand or up-scale (Jaisinghani, 2011). Given the nascent development status of the sector, formal financial organisations are generally reluctant to lend to this sector. The sector is considered high-risk for investors. Risks associated with the financing of projects are related to making these projects bankable. Given these projects operate in rural settings with poor consumer load profiles and without any long-term power purchase agreements in the majority of cases, banks are usually reluctant to finance these interventions. Further, high upfront costs have also been acting as a major deterrent. Therefore, debt-financing from banks becomes a cumbersome affair for private investors and they are also reluctant to finance these projects without having sufficient collateral and risk guarantees. This is primarily because they perceive high technological and financial risks, and a lacking history of profit-making by entrepreneurs. In addition, the small size of the projects also makes it difficult for the project developers to attract equity finance. Again, this is due to the perceived problems of project scalability and long pay-back periods. This gets compounded by a lack of bankable business models in the sector, even with the publicly supported schemes.

Jaisinghani (2011) also argues that non-uniform technical approaches, and under-developed non-technical processes (such as tariff collection and responses to system abuse), further hinder access to finance at the early stage of projects and hamper off-grid electrification. Since all these private mini-grid developers are new to the field with limited practical experience (e.g. HPS has been operating for five years, and MGP for three), they confront several challenges. They are also vulnerable to a wide range of technology-centric risks. It was felt during the discussion with the project devel-



Lighting in a beneficiary household, Village Kumedhin, Madhya Pradesh, India.

operators that some sort of standardisation is required in order to address the technical problems and bring about uniformity in the technology interventions, which will ultimately lead to minimising the associated technological risks.

Often, weak institutional structures and organisational systems contribute to the poor performance of the projects. Cust et al. (2007) argue that even economically viable projects can fail simply because of an inadequate appreciation of the importance of appropriate organisational structures and institutional arrangements. Past experiences also show

that a large number of off-grid electrification projects have had limited success (especially VESP) because of the disproportionate focus on technical installation without adequate attention to the long-term sustainability of the projects (Kumar et al., 2007). A typical example is that of VESP projects, implemented by numerous NGOs and state government agencies, where there was a lack of clarity on the roles and responsibilities among different stakeholders that resulted in sub-optimal community participation and the failure of most of the projects (Palit, 2011).

Conclusions and lessons learned

Based on the experiences of the mini-grid models and a review of examples, we present five main conclusions for energy development practitioners, project developers and policymakers.

Institutional

The mini- and micro-grids in India are mainly community-centric projects or involve NGOs, and thus lack an organised delivery approach compared to utility-driven, conventional grid-based supply systems. The community-based service model of the mini-grid projects, while democratic and decentralised, presents its own challenges. Most of the community-based projects were implemented on the premise that the community (through the VEC) or the local *panchayat* own the project and assume overall responsibility for management and operations. This model may be suitable for those remote areas where the strength of local governance is reasonably good and there is better social cohesiveness in the village. However, as discussed in previous sections, the VEC is found to be weak in many cases and group activity can be minimal. This can be a limitation of the current institutional edifice of managing mini-grids, as implementation metrics and operational practices differ from organisation to organisation, and agencies are not all able to benefit from a standardised set of implementation guidelines or protocols. It is, however, observed that community buy-in and acceptance, and the ability to see the benefits, have contributed to the success of some projects. The community approach has been more successful in projects that have focused on improving the productive uses of electricity, such as in the case of the Sunderbans and HPS. It is learnt from these particular examples that collecting revenues is comparatively more successful where villagers receive some income, either because of their existing income-generating activities or from newly created activities resulting from electrification made through interventions. Moreover, divided ownership models, where operation and revenue collection are conducted by separate verticals and/or different individuals, seem to bring better focus on generation and service delivery.

It is suggested that service delivery models need to be designed and structured in such a way as to recognise the uniqueness of each region. While technical features will require a degree of standardisation, a uniform delivery model might prove counterproductive. There is also a need for standard contracts and implementation processes for the mini-grid projects to keep transaction costs low. Instead of the VEC model, alternative service delivery models involving Energy Service Provider (ESP) or BOOM and BOM models could be piloted. The ESP, based on an entrepreneurial model, could play the collective role of the stand-alone power producer, distributor and supplier of electricity and manage the revenue through payment collection from electricity users. The VEC, with appropriate training and exposure, can act as a local-level regulator to oversee that the standards and benchmarks are being followed by the ESP or service providers, negotiate the tariff and biomass prices (in cases of local sourcing of biomass for a biomass project), and resolve disputes between (or any grievances of) consumers and service providers. This model will also be appropriate for not-so-remote villages, covering a large number of residential and commercial consumers to ensure financial viability.

Choice of technology

The choice of technology and designing their capacity in the context of renewable energy-based mini-grid projects are seen to have been influenced by various actors and factors, such as the geographic and climatic conditions prevailing in the region, the prevailing policy and incentive frameworks promoting different technologies at varying levels, the presence or absence of supply chains for different technologies at the local scale, and finally the socio-economic profiles of households at the very micro level. For example, it was observed from field studies that a sufficient and steady fuel supply, especially through local community involvement, is critical for the sustainability of biomass gasifier-based mini-grids. Similarly, in the case of solar mini-grids, the storage batteries are found to be the technically vulnerable part of the systems, which therefore require proper management



Distribution line in village Rampura, Madhya Pradesh, India.

and routine servicing. This has created additional challenges for the whole operation and sustainability of the solar mini-grids in the Sunderbans region. They are difficult to operate, which creates a need for the advanced development of operators' technical understanding, and further requires appropriate drawing of electricity by consumers according to set norms to extend battery life. All these challenges illustrate the close interconnections that exist between technical and non-technical matters, and thus the importance of focusing on these connections to obtain viable solutions. The study suggests that the selection of technology should be based not only on robustness, but also on the availability of knowledge and skill-sets of local people so that after-sales service and maintenance can be locally managed and rarely outsourced.

It could also be observed from the Indian experiences of mini-grids that the modularity of technological options has enabled projects to have different capacities, which have been determined by the particular needs and requirements

of the local communities. For instance, the Sunderbans and Lakshadweep Islands, which have very high population densities, have set up local mini-grids with medium to large capacity off-grid solar power plants (more than 100kW_p capacity and covering more than two hundred households per plant). On the other hand, almost all the mini-grids in Chhattisgarh are of less than 6kW_p capacity and are mostly implemented in sparsely populated, tribal habitations.

On the technology front, another pertinent issue is related to the risk of obsolescence. This holds paramount importance in the context of grid-reaching in the off-grid locations, which renders the projects obsolete. However, it appears from the policy sphere governing the off-grid energy sector in India that there have always been efforts to accommodate new and emerging technologies with changing needs and priorities. In its early phases (1996-2002), most mini-grids were designed to operate only in stand-alone mode, though they were using state-of-the-art inverter-converter systems of the time. With the launch of the DDG scheme under Ra-

jiv Gandhi Grameen Vidyutikaran Yojana in 2009, the provision of grid-compatible power conditioning-units have been made mandatory in the design of any project, so that as and when the conventional grid reaches the site, these mini-grids can simply be connected and kept functional. In addition, smart-grid technology⁶ has also recently evolved so that existing renewables-based generators in mini-grids may be seamlessly connected to the conventional grid, and any number of renewable energy-generators may be connected to the mini-grid to supply electricity to the local area, improving electricity access in the region.

Cluster approach for implementation

Renewable energy-based mini-grids require clusters or certain economies of scale to work properly. One cannot promote mini-grid projects in the same manner as renewable energy individual products and solutions, such as solar home systems or solar lamps. In the particular case of the biomass-based projects, community-scale ambitions did not always match the realities of local fuel supply. Depending on the proximity of the habitations, the merit of establishing a standardised capacity of local mini-grids or centralised power plants of higher capacity could be beneficial over smaller capacity systems for certain technologies. In addition to appropriate scaling, the optimal implementation of mini-grid technologies require readily available spare parts and machinery for plant and equipment, reliable after-sales services at the locations where projects are planned, properly trained individuals for systems operation and maintenance, and applicable laws and regulations that allow and support the projects. In the case of biomass-based technologies, there should be sufficient extractable feed material available locally for their sustained generation. Experiences from the case studies discussed in this paper clearly highlight that a structured development of the maintenance network has assisted in the sustained operation of mini-grid projects. For example, CREDA has been successfully running mini-grid projects in remote locations mainly using a cluster approach for O&M. In addition to clustering, bundling of projects can be helpful in minimizing the transaction costs associated with securing carbon benefits. There have been efforts by private mini-grid

developers such as HPS to capitalise on the bundling of projects to obtain venture capital funding as well as such carbon benefits, and to take advantage of cluster-based approaches.

Enabling policy and regulatory environment

The rate of success of mini-grids is directly dependent on the Government's commitment to creating an enabling environment in a sustainable manner, which includes having a clear cut policy framework and milestones, systems for defining and enforcing appropriate standards, financial support mechanisms and support for capacity-building. Enabling policies have been developed from time to time to mainstream mini-grid systems as an effective alternative to electricity supply. Recently, a key amendment was made in the DDG scheme guidelines to include implementation of DDG projects in all areas including grid-connected areas, which are getting less than six hours of supply from the grid in addition to the areas that are not connected through any grid-based supply. The revised scheme further allows the project developer and electricity distribution companies (discom) the following possible relationship:

- i. When DDG projects are being implemented in remote areas where no grid is available, the project developer shall have no connection with the discom;
- ii. When the developer is using only the distribution network of the discom, they shall pay only the wheeling charges to the discom for using their distribution network
- iii. When the developer is supplying in the area where the discom is already supplying electricity, mutually agreed terms shall be worked out by the developer to become a franchisee of the discom for the collection of tariffs.

In spite of the above, some lacunae continue to persist in the policy and regulatory sphere. For instance, the existing legal and regulatory enshrinements allow cross-subsidies to be limited to the grid-based consumers, while mini-grid consumers do not get the similar facility. This hinders the creation of a level playing-field between the grid-supplied utilities and service providers of mini-grid modalities. Thus, the mini-grid projects often become unviable, as they cannot compete with the tariffs prevailing in neighbouring grid-connected villages (which are cross-subsidised through regulatory intervention). Therefore,

⁶ Smart-grid technology offers ways of integrating off-grid/decentralised energy systems with the centralised grid system in a rational and balanced manner. For instance, off-grid generation systems could be controlled and dispatched by the central control center, and could be tapped during peak hours. Usually the incremental cost for introducing smart systems may range from 10 percent and over depending on the level of smartness introduced.

a mechanism is required from electricity regulators to set the tariff levels for mini-grid projects, and provide subsidies to the project developers or service providers from a universal service obligation fund. Even though the word ‘subsidy’ has become unpopular in electricity sector reforms, it still has relevance in many cases in view of the need to electrify low-demand, inaccessible rural areas. For instance, in the case of Chhattisgarh, a proactive policy initiative by the state government towards meeting the lifeline tariff for mini-grid projects, similar to that followed for central grid-connected consumers, has been one of the key drivers for the successful operation of mini-grid projects in the state. The universal access fund can provide capital and operating subsidies with competitively determined, output-based aid targeted at the ‘base of pyramid’ consumers, along with differential tariffs to bridge any financial viability gap. The fund can be created through a suitable mechanism from the cross-subsidisation amount and/or deploying savings from the reduction in kerosene subsidies, which are otherwise used for lighting in such un-electrified villages. However, for such cases, a monitoring mechanism must be developed to see that only the functional plants are beneficiaries of such subsidies and operators/utilities accept certain commitments to service obligations and tariffs. The distribution utilities that include the cross-subsidy in their annual revenue requirement when making submissions to the regulatory commission can also show these mini-grid projects to meet their renewable power obligations (Palit et al., 2011).

Further, to augment the electricity supply situation in grid-connected rural areas and also achieve better operational efficiency, distributed power generation can be combined with a suitably structured electricity delivery model for better utilisation of the rural electricity distribution infrastructure. As the grid supply situation improves, these operators can become franchisees of the distribution utilities and continue to serve the areas, partly with local generation and partly from the grid supply at a weighted average cost of supply. An interesting aspect of policy-level incentives on similar lines is traced to the recent emphasis on bringing the sector under regulatory purview. It offers two new guidelines for introducing regulation by the regulatory commissions. One is a distribution franchisee system based on a feed-in-tariff scheme, and is known as Off-Grid Distributed Generation-based Distribution Franchise model, and the other is the Renewable Energy Certificate model for off-grid generation to address the viability gap. The whole idea

is to introduce market mechanisms by decoupling end-user tariffs and project viability. The draft guideline allows developers either to function independently of the electricity distribution companies and serve consumers on a mutually agreed price, or as a franchisee of the distribution companies where the quantity of electricity generated could go toward fulfilling the renewable purchase obligations of the distribution companies. The policy is still under discussion and has yet to be notified for implementation.

Local capacity-building

The local capacity-building of stakeholders has ensured better project performance, as observed in the Indian cases. The operators of the power plants/mini-grids play a vital role in ensuring the plants’ long-term operation. In addition to good technical solutions, the dedication and skill, and the ability to make good decisions in daily O&M are crucial for the performance of a whole energy supply system so as to best benefit community members. Merely providing training to the remote communities may not address all issues, as community members may not grasp a proper understanding of the technology because of their lack of exposure and familiarity. Further, the experience also indicates that there is a need to train operators not only during the initial phases of plant operation, but also provide them refresher-training programmes at regular intervals. In addition, enhancing awareness among the beneficiaries of the plant is also found to be helpful. Often, active community mobilisation and empowerment allowed for improved integration of the O&M systems within the community structure. Further, the evidence drawn from the mini-grid experience reveals that appropriate support systems should be an integration of a strong “participatory governance system” at the local level and a “well-knitted hierarchical system connecting local level management with the top level management regimes”. While issues that are local in nature could be better addressed through participatory governance systems, the issues relating to policy, regulatory and financing can be well managed through a graded system with appropriate intermediary and/or higher-level management regimes. It is important to design support systems to ensure that plans and policies dynamically match the needs of all stakeholders, i.e. consumers, owners and technology suppliers, etc. over a period of time.

References

- Bhattacharyya, S. C. (2006). Energy access problem of the poor in India: Is rural electrification a remedy? *Energy Policy*, 34: 3387-3397.
- Chaurey, A., Ranganathan, M. & Mohanty, P. (2004). Electricity access for geographically disadvantaged rural communities: Technology and policy insights. *Energy Policy*, 32(15): 1693-1705.
- Cust, J., Singh, A. & Neuhoff, K. (2007). Rural electrification in India: Economic and institutional aspects of renewables. *EPRG 0730 and CWPE 0763*. Retrieved from <http://www.eprg.group.cam.ac.uk/wp-content/uploads/2008/11/eprg0730.pdf>.
- ESMAP. (2007). Technical and economic assessment of off-grid, mini-grid and grid electrification technologies. *Technical Paper 121/07*.
- IEA. (2012). World Energy Outlook. Paris: International Energy Agency.
- Jaisinghani, N. (2011). Islands of light: The experience of micro-grid power solutions. *Solar Quarterly*, 3(3): 10-18.
- Kumar, A., Mohanty, P., Palit, D. & Chaurey, A. (2009). Approach for standardization of off-grid electrification projects. *Renewable Sustainable Energy Rev*, 13: 1946-56
- MNRE. (2013). Remote Village Electrification Programme (as of 30 June 2013). Ministry of New and Renewable Energy, Government of India, New Delhi. Retrieved from <http://mnre.gov.in/file-manager/UserFiles/physical-progress-of-RVE-programme.pdf>. Last accessed 30 December 2013.
- Palit. (2011). Performance assessment of biomass gasifier based power generation systems implemented under village energy security programme in India. In *Proceedings of the International Conference Advances in Energy Research; December 9-11, 2011*. Mumbai: Indian Institute of Bombay
- Palit, D. Malhotra, R. & Kumar, A. (2011). Sustainable model for financial viability of decentralized biomass gasifier based power projects. *Energy Policy*, 39: 4893-4901.
- Palit, D. & Chaurey, A. (2011). Off-grid rural electrification experience from South Asia: Status and best practices. *Energy for Sustainable Development*, doi:10.1016/j.esd.2011.07.004.
- Palit, D. (2013). Solar energy programs for rural electrification: Experiences and lessons from South Asia. *Energy for Sustainable Development*, 17(3): 270-279.
- Radulovic, V. (2005). Are new institutional economics enough? Promoting photovoltaics in India's agricultural sector. *Energy Policy*, 33(14): pp 1883-1899.
- Rao, N. D. (2013). Does (better) electricity supply increase household enterprise income in India? *Energy Policy*, 57: 532-541.
- Shrank, S. (2008). *Another look at renewables on India's Sagar Island*. (Working Paper #77, July 2008). Program on Energy and Sustainable Development (PESD), Stanford University.
- Siddiqui, S. & Upadhyay, S. (2011) Need for integrated policy and institutional framework for the implementation of Jawaharlal Nehru National Solar Mission in rural areas. A Report of ELDF and Heinrich Boll Stiftung, India.
- Ulsrud, K., Winther, T., Palit, D., Rohracher, H. & Sandgren, J. (2011). The solar transitions research on solar mini-grids in India: Learning from local cases of innovative socio-technical systems. *Energy for Sustainable Development*. doi:10.1016/j.esd.2011.06.004.
- Yin, R. K. (2003). *Case study research: Design and methods*. Thousand Oaks: Sage.